

全自動L型封口機

AUTOMATIC L-TYPE SEALING MACHINE

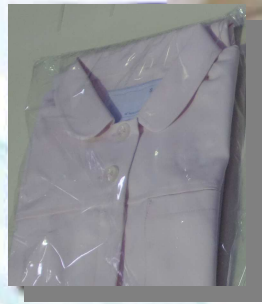

L-PACK-120C



東都フォルダー工業 株式会社
TOTO FOLDER MANUFACTURING CO.,LTD.

AUTOMATIC L-TYPE SEALING

L-PACK-120C Specifications

Feature

The automatic L type sealing machine "L-PACK-120C" can pack the folded-up linen automatically. By connecting with our uniform folder and blanket folder, the automation line from folding to packing is realized, and it contributes to reduction of personnel expenses greatly.

There are the following features in "L-PACK-120C."

- ◆ Equipped with safety protection & alarm, heavy duty sealing knives, no build-up & smoke whilst sealing.
- ◆ Easy operation & adjustment.
- ◆ High efficiency for labor cost saving.
- ◆ Extra pinch roller guide for better film control and saving.
- ◆ PLC control system with 2 programs, length controlled by either photo eyes or timers.
- ◆ Independent perforating rod, easy adjustment, no tearing line.
- ◆ Welding and cutting of film material are performed simultaneously and it is high throughput.

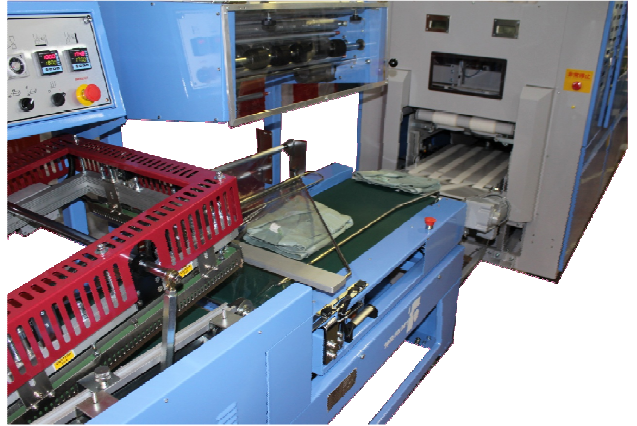

The automatic packaging line connected with uniform folder WFO-JUMP-HG

Specifications

- ◆ Machine Size: 2100Lx940Wx1580H mm
- ◆ Package Range
(30~500)x(60~300)x(5~120) (LxWxH mm)
- ◆ Speed Range: 1 ~ 18Pcs/M
- ◆ Power: 200V 2phase
- ◆ Consumption: 2KW
- ◆ Conveyor height: 750mm
- ◆ Width of input conveyor: 390mm
- ◆ Width of output conveyor: 350mm
- ◆ Recommended film
 - * Material of film : Polyolefin = POF
 - * Film thickness : 0.015 mm
 - * Film width per reel : 8- 25 inches (210-635mm)
 - * Multi layers
 - * Molting Temperature : 170-180 degree.

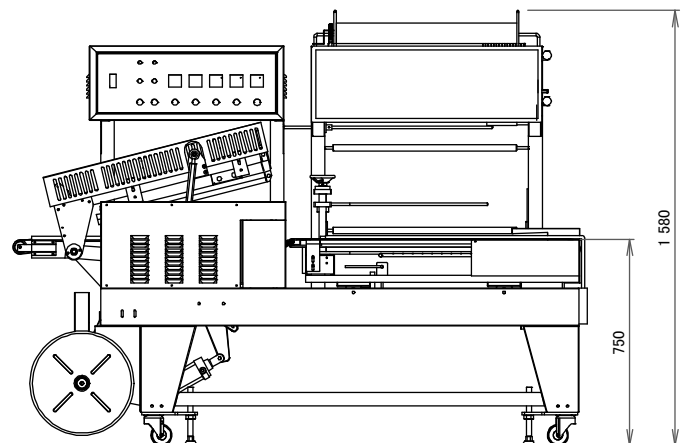
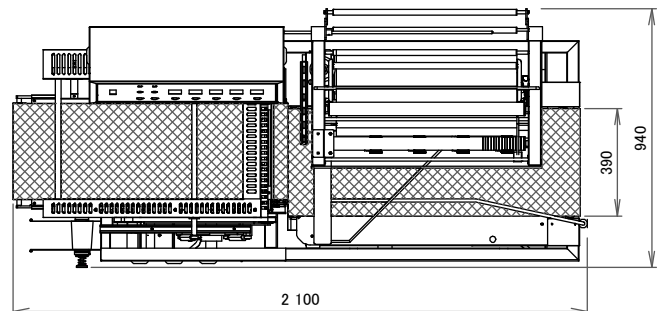

TOTOFOLDER MANUFACTURING CO., LTD.

2-8-75 YOSHINODAI KAWAGOE CITY SAITAMA JAPAN

Phone: 049-225-6125 Fax: 049-225-6127

◇<http://www.totofolder.jp/> ◇tf-main@totofolder.jp

代理店